

For standby power supplies  
 Expected trickle life: 3 years at 25°C  
 5 years at 20°C

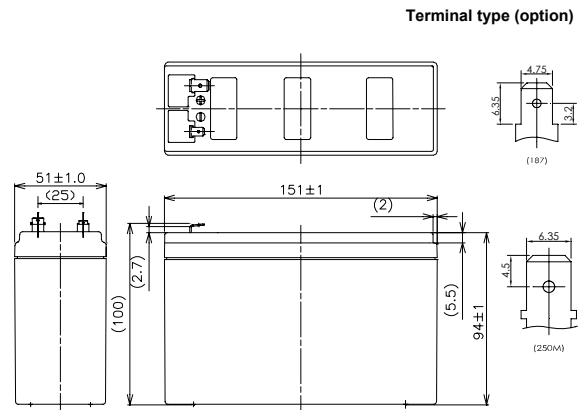

※Contents indicated (including the recycle marking, etc) are subject to change without notice.

### ■Dimensions(mm)



Battery case resin: Flame-retardant (UL94V-0)

### ■Specifications

Nominal Voltage		12V
Rated Capacity(cell@10MR)		32W
Dimensions	Length	151 mm
	Width	51 mm
	Height	94 mm
	Total height	100 mm
Approx. Mass		2.00 kg
Terminal		Faston 187 & 250M

### ■Characteristics

Capacity (25 °C)	30 minute rate	97W
	15 minute rate	165W
	10 minute rate	210W
	5 minute rate	339W
Internal Resistance (25 °C)	Fully charged battery	25 mΩ
Temperature Dependency of Capacity (20 hour rate)	40 °C	102%
	25 °C	100%
	0 °C	85%
	-15 °C	65%
Self Discharge (25 °C)	After 3 months	91%
	After 6 months	82%
	After 12 months	64%

### ■Duration of discharge vs. discharge current

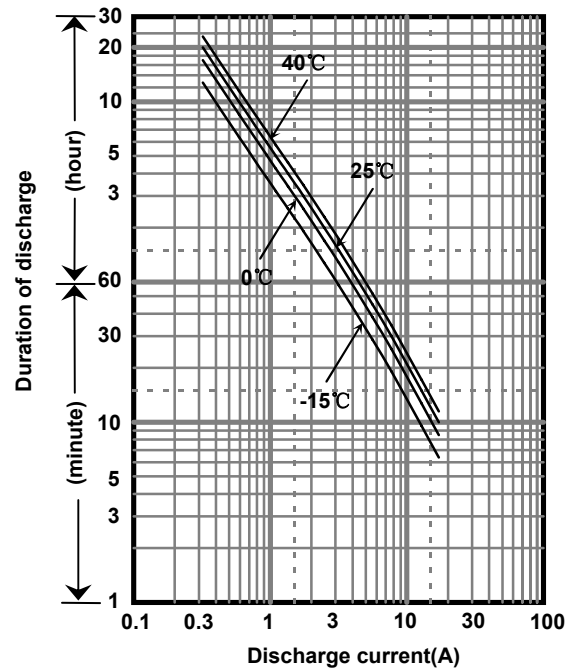

### ■Watt Table(25°C)

Cut-off V	(Wattage/Battery)															
	3min	5min	10min	15min	20min	30min	45min	1h	1.5h	2h	3h	4h	5h	6h	10h	20h
9.6V	444	339	210	165	130	97.0	71.1	56.9	41.8	31.5	22.5	16.6	13.8	11.7	7.39	3.86
9.9V	418	290	179	157	127	95.0	70.7	55.5	40.9	31.3	22.4	16.5	13.7	11.4	7.36	3.85
10.2V	391	276	174	149	124	93.0	67.7	53.9	38.8	29.6	21.5	15.9	13.2	11.2	7.04	3.72
10.5V	355	251	166	143	118	89.5	65.9	52.8	37.3	28.6	20.3	15.8	13.1	11.1	7.01	3.71
10.8V	318	226	157	137	113	86.0	61.7	48.8	34.8	25.5	19.5	14.6	12.0	10.3	6.53	3.47

### ■Ampere Table(25°C)

Cut-off V	(Ampere/Battery)															
	3min	5min	10min	15min	20min	30min	45min	1h	1.5h	2h	3h	4h	5h	6h	10h	20h
9.6V	36.9	27.8	17.1	13.7	11.0	8.29	6.06	4.83	3.31	2.56	1.89	1.45	1.19	0.958	0.634	0.344
9.9V	34.7	26.5	16.7	13.0	10.7	8.12	6.02	4.71	3.25	2.54	1.88	1.44	1.18	0.954	0.631	0.343
10.2V	32.5	25.2	16.3	12.3	10.3	7.95	5.77	4.58	3.08	2.40	1.80	1.38	1.14	0.916	0.604	0.331
10.5V	29.5	22.9	15.5	11.8	9.90	7.65	5.61	4.48	2.96	2.32	1.76	1.33	1.07	0.906	0.602	0.320
10.8V	26.4	20.6	14.6	11.3	9.48	7.35	5.26	4.14	2.76	2.07	1.64	1.28	1.03	0.838	0.560	0.309

All mentioned values are average values

**Charging Method (25°C)**

Trickle use	Control voltage:13.6-13.8V Initial current:0.900A or smaller
-------------	---

**Cut off voltage**

Discharge current	0.300A-1.20A	1.20A-3.00A	3.00A-6.00A	6.00A-12.0A	12.0A-18.0A
Cut off voltage(V)	10.5	10.2	9.9	9.3	8.7

**Influence of Temperature on Trickle life**

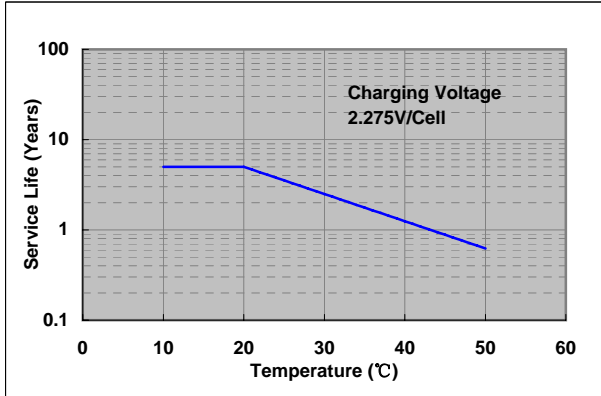

**Residual capacity test result**

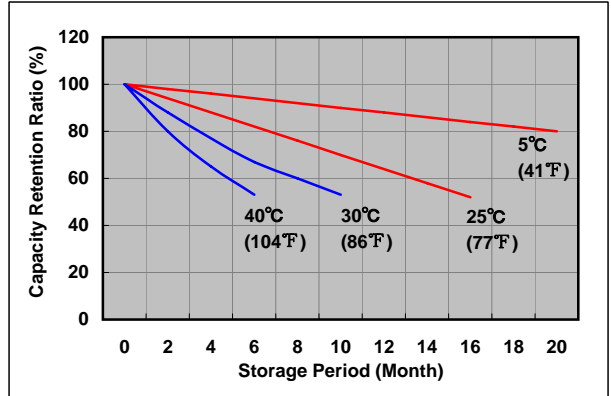

**Constant-voltage constant-current charge characteristics for Trickle use**

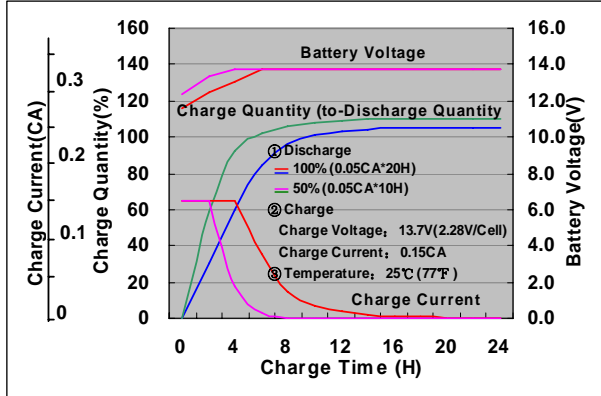

**Discharge capacity by temperature and by discharge current**

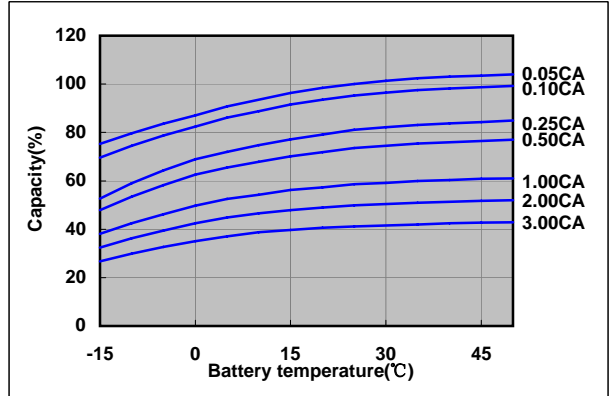

**Discharge characteristics(25°C)**

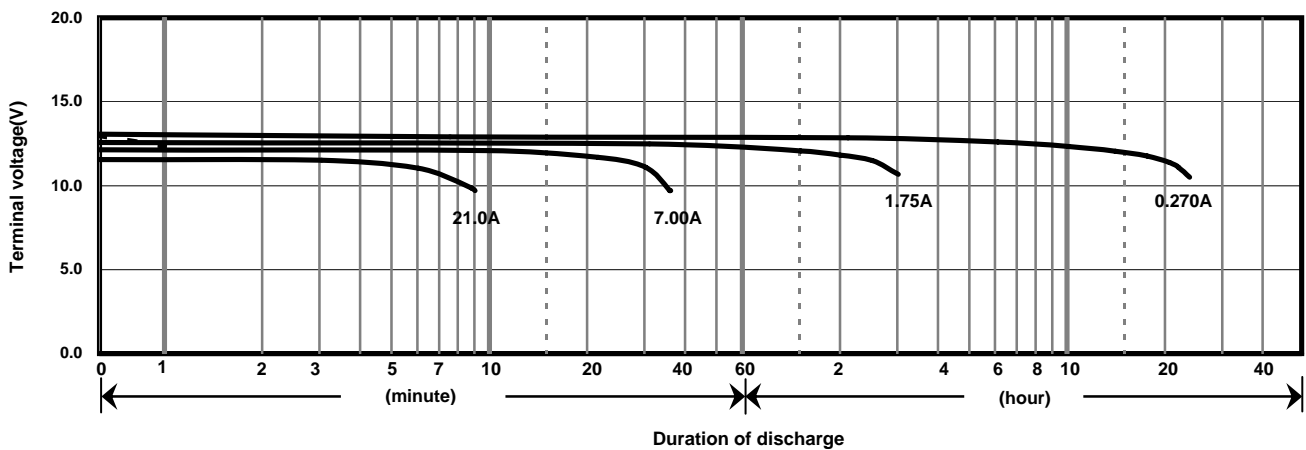

**Caution**

Due to the potential energy stored in the batteries, Please read 《Precautions for handling the Rechargeable Valve Regulated Lead Acid Batteries》 before using batteries. If improper handling or use of the batteries without understanding 《Precautions for handling the Rechargeable Valve Regulated Lead Acid Batteries》 may result in bodily injury caused by electrolyte leakage, heat generation, or explosion.

**Panasonic Storage Battery (Shenyang) Co., Ltd**

NO. 17 Hunhe 20Th Street, Shenyang Economic & Technical Development Zone,110142 China

Tel: 86 24 25818921

Fax: 86 24 62786318

Website: <http://www.panasonicbattery.cn>

2015.01