



VISION GROUP
Shenzhen Center Power
Tech.Co.Ltd.,

6FM100E-XV

12V 100Ah(10hr)

Overview

The rechargeable batteries are lead-lead dioxide systems. The dilute sulfuric acid electrolyte is absorbed by separators and plates and thus immobilized. Should the battery be accidentally overcharged producing hydrogen and oxygen, special oneway valves allow the gases to escape thus avoiding excessive pressure build-up. Otherwise, the battery is completely sealed and is, therefore, maintenance-free, leak proof and usable in any position.



Battery Construction

Component	Positive plate	Negative plate	Container	Cover	Safety valve	Terminal	Separator	Electrolyte
Raw material	Lead dioxide	Lead	ABS	ABS	Rubber	Copper	Fiberglass	Sulfuric acid

General Features

- Absorbent Glass Mat (AGM) technology for efficient gas recombination of up to 99% and freedom from electrolyte maintenance or water adding.
- Not restricted for air transport-complies with IATA/ICAO Special Provision A67.
- UL-recognized component.
- Can be mounted in any orientation.
- Computer designed lead, calcium tin alloy grid for high power density.
- Long service life, float or cyclic applications.
- Maintenance-free operation.
- Low self discharge.
- Case and cover available in both standard and flame retardant ABS.

Dimensions and Weight

Length(mm / inch)	339/13.35
Width(mm / inch)	173/6.81
Height(mm / inch)	214.5/8.44
Total Height(mm / inch)	220/8.66
Approx. Weight(Kg / lbs)	27.5 /60.6

* Weight deviation: $\pm 5\%$

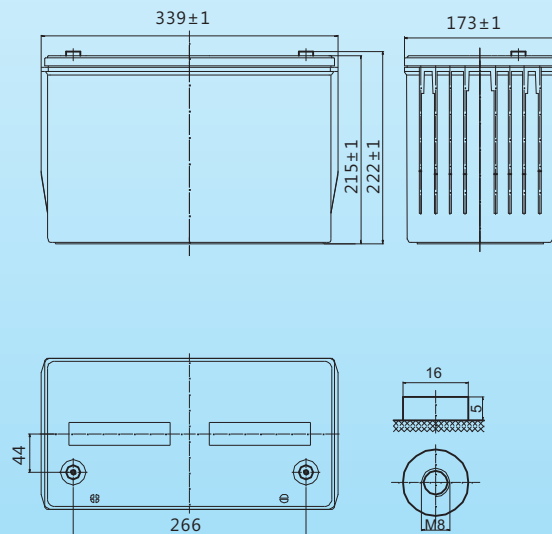

Battery Specification

Performance Characteristics	
Nominal Voltage	12V
Number of cell	6
Design Life	10 years
Nominal Capacity 77°F(25°C)	
10 hour rate (10.0A, 10.8V)	100Ah
5 hour rate (17.5A, 10.5V)	87.5Ah
1 hour rate (66.2A, 9.6V)	66.2Ah
Internal Resistance	
Fully Charged battery 77°F(25°C)	≤ 5.7 mOhms
Self-Discharge	
3% of capacity declined per month at 20°C (average)	
Operating Temperature Range	
Discharge	-20~60°C
Charge	-10~60°C
Storage	-20~60°C
Max. Discharge Current 77°F(25°C)	900A(5s)
Short Circuit Current	2500A
Charge Methods: Constant Voltage Charge 77°F(25°C)	
Cycle use	2.40-2.45VPC
Maximum charging current	30.0A
Temperature compensation	-30mV/°C
Standby use	2.20-2.30VPC
Temperature compensation	-20mV/°C

Discharge Constant Current (Amperes at 77°F25°C)

End Point Volts/Cell	Time							
	10min	15min	30min	1h	3h	5h	10h	20h
1.60V	229	185	108	66.2	27.9	19.0	10.8	5.50
1.65V	221	178	104	62.5	27.7	18.3	10.6	5.45
1.70V	200	164	96.0	61.5	27.2	18.0	10.5	5.40
1.75V	187	153	93.0	60.5	26.9	17.5	10.3	5.35
1.80V	175	143	91.0	57.4	25.3	17.2	10.0	5.30

Discharge Constant Power (Watts at 77°F25°C)

End Point Volts/Cell	Time							
	10min	15min	30min	45min	1h	2h	3h	5h
1.60V	392	321	199	150	124	52.8	35.8	20.3
1.65V	379	315	188	146	118	51.2	35.4	20.1
1.70V	360	299	183	137	114	50.9	35.0	20.0
1.75V	353	294	177	134	111	49.1	34.4	19.6
1.80V	329	279	171	131	104	48.5	34.0	19.1

(Note) The above characteristics data are average values obtained within three charge/discharge cycles not the minimum values. All data shall be changed without notice, Vision reserves the right to explain and update the information contained hereinto.



VISION GROUP
Shenzhen Center Power
Tech.Co.Ltd.,

6FM100E-XV

12V 100Ah(10hr)

